

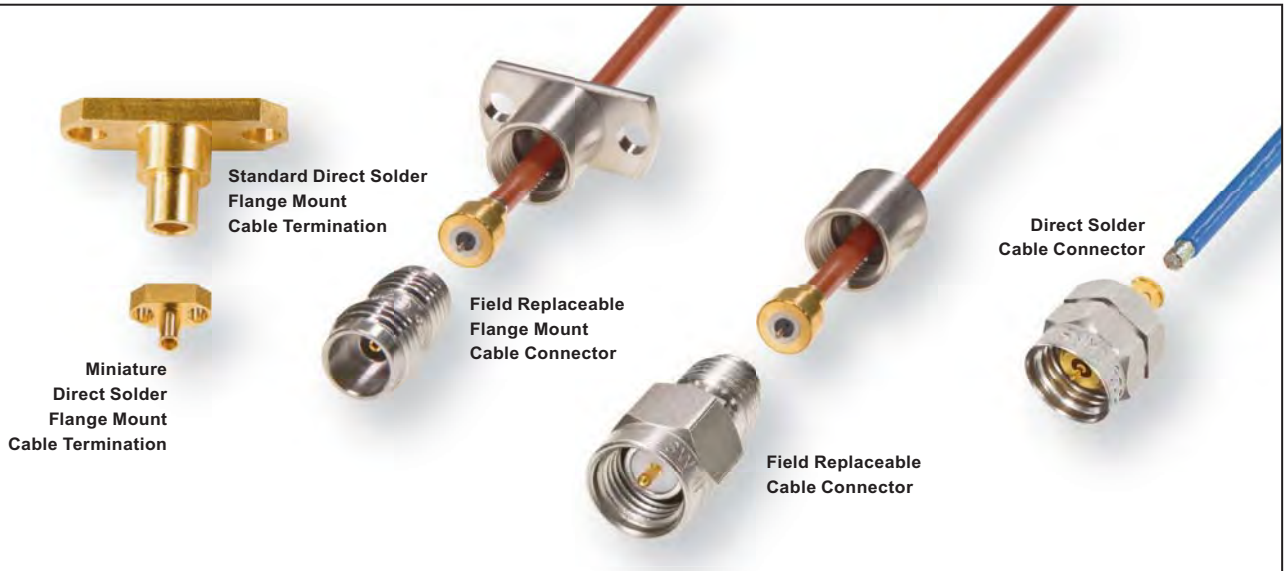

Cable Connectors



Index

Cable Connectors	Page
Cable Connectors (Features & Benefits)	67
Field Replaceable	68
Direct Solder	
Cable Connectors	70
Flange Mount Cable Terminations	72

Unless otherwise specified, all dimensions are in inches.

Field Replaceable Cable Connectors

Features & Benefits:

- Center conductor of the cable launches into the rear female socket of the connector
- Built-in stress relief accommodates cable center conductor movement
- Cable connectors easily replaced without unsoldering
- Interchangeability of connector types for unsurpassed flexibility
- More consistent electrical performance by eliminating the solder variable on the center conductor

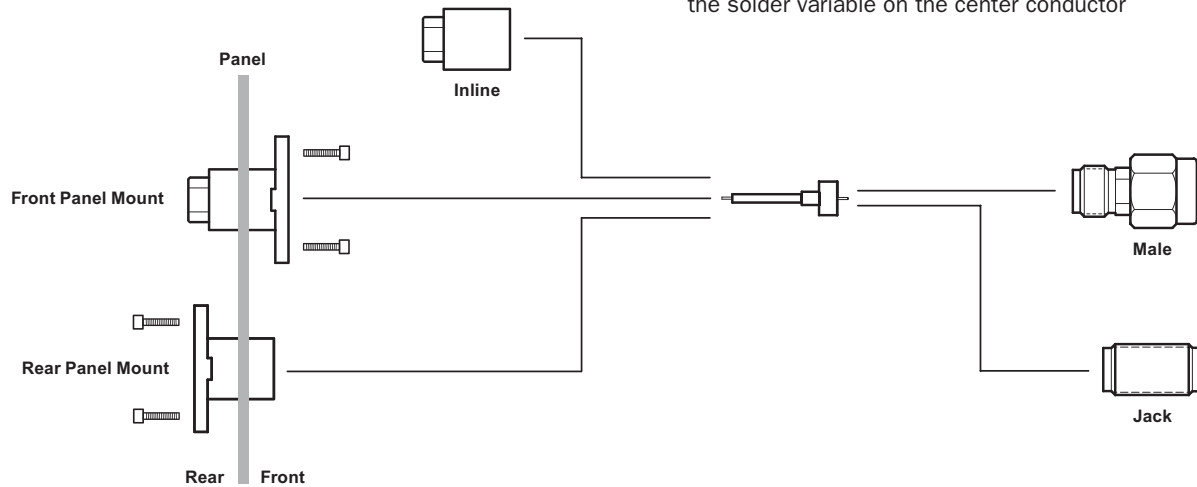

Direct Solder Cable Connectors & Terminations

Features & Benefits:

- Center conductor of the cable launches into the rear female socket of the connector
- Inspection hole on the outer conductor
- Built-in stress relief accommodates cable center conductor movement
- More consistent electrical performance by eliminating the solder variable on the center conductor
- Inspection hole insures proper insertion of the cable center conductor

Inline Connectors

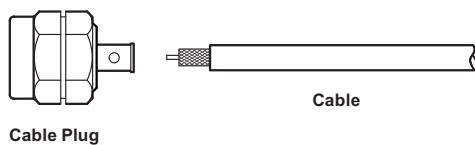

Flange Mount Terminations

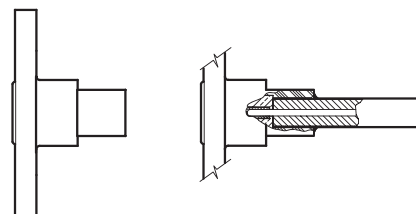

Users are cautioned that performance is dependent upon the specific cable selected and cable preparation and termination, which is beyond the control of Southwest Microwave.



Field Replaceable Cable Connectors

Materials & Finishes

Materials:

- Connectors: (refer to appropriate catalog section)
- Cable Nut: Stainless Steel, UNS S30300 Per ASTM A582
- Cable Adapter: Brass Alloy, UNS C36000 Per ASTM B16

For Female Installation Tool
(See Installation and Tools).

Environmental:

- Operating Temperatures: (refer to appropriate catalog section)

Recommended Installation
Torque is 15–18 in-lbs.

Inline

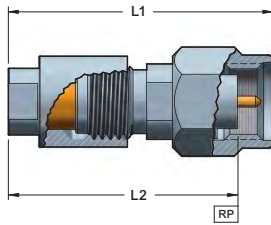

2.40 mm	.88	.80
2.92 mm	.86	.74
SSMA	.88	.76
SMA	.87	.76
Series	L1	L2

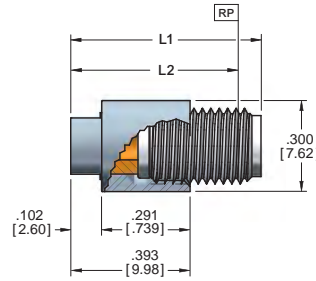

2.40 mm	.68	.56
2.92 mm	.63	.55
SSMA	.60	.53
SMA	.65	.57
Series	L1	L2

Front Panel Mount

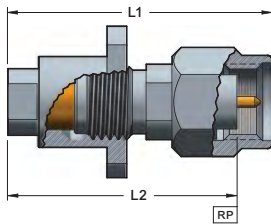

2.40 mm	.88	.80
2.92 mm	.86	.74
SMA	.87	.76
Series	L1	L2

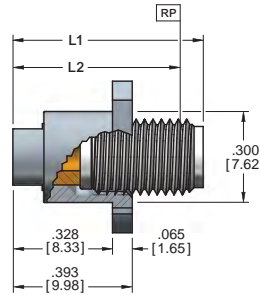

2.40 mm	.68	.56
2.92 mm	.63	.55
SMA	.65	.57
Series	L1	L2

Rear Panel Mount (Maximum Panel Thickness is .345")

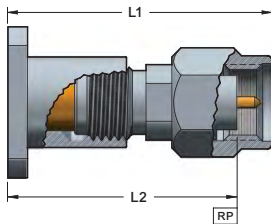

2.40 mm	.88	.80
2.92 mm	.86	.74
SMA	.87	.76
Series	L1	L2

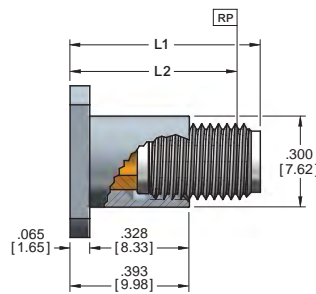

2.40 mm	.68	.56
2.92 mm	.63	.55
SMA	.65	.57
Series	L1	L2

Dimensions

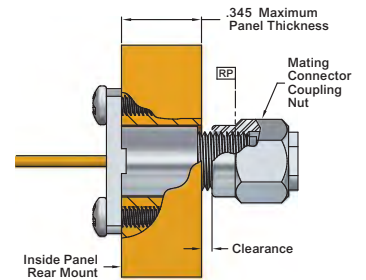
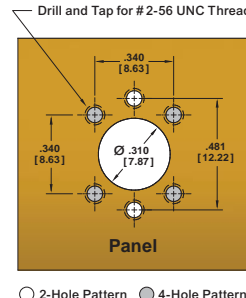
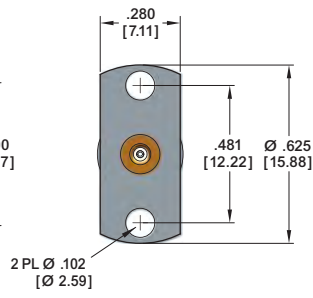
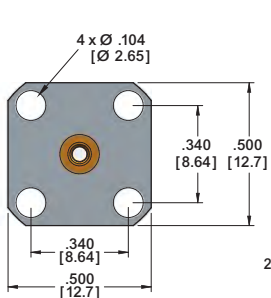

Super SMA Connector Kits (DC to 27 GHz)	Cable Center Conductor Dia.	Cable	Inline Connector Kit No.		2H .625 Front Panel Mount Connector Kit No.		2H .625 Rear Panel Mount Connector Kit No.	
	.012	.047	201-500SF	202-500SF	201-517SF	202-514SF	201-515SF	202-512SF
	.020	.086	201-502SF	202-502SF	201-513SF	202-510SF	201-511SF	202-508SF
	.036	.141	201-503SF	202-503SF	201-509SF	202-506SF	201-507SF	202-504SF
			Male	Female	Male	Female	Male	Female
SSMA Connector Kits (DC to 36 GHz)	Cable Center Conductor Dia.	Cable	Inline Connector Kit No.		2H .625 Front Panel Mount Connector Kit No.		2H .625 Rear Panel Mount Connector Kit No.	
	.012	.047	101-01SF	102-01SF	-	-	-	-
	.020	.086	101-02SF	102-02SF	-	-	-	-
			Male	Female	Male	Female	Male	Female
2.92 mm Connector Kits (DC to 40 GHz)	Cable Center Conductor Dia.	Cable	Inline Connector Kit No.		2H .625 Front Panel Mount Connector Kit No.		2H .625 Rear Panel Mount Connector Kit No.	
	.012	.047	1001-03SF	1002-03SF	1001-16SF	1002-16SF	1001-10SF	1002-10SF
	.020	.086	1001-04SF	1002-04SF	1001-15SF	1002-15SF	1001-17SF	1002-17SF
			Male	Female	Male	Female	Male	Female
2.40 mm Connector Kits (DC to 50 GHz)	Cable Center Conductor Dia.	Cable	Inline Connector Kit No.		2H .625 Front Panel Mount Connector Kit No.		2H .625 Rear Panel Mount Connector Kit No.	
	.012	.047	1401-01SF	1402-01SF	1401-11SF	1402-11SF	1401-09SF	1402-09SF
	.020	.086	1401-02SF	1402-02SF	1401-07SF	1402-07SF	1401-05SF	1402-05SF
			Male	Female	Male	Female	Male	Female



Direct Solder Cable Connectors

Super SMA (27 GHz), **SSMA** (40 GHz), **2.92 mm** (40 GHz), **2.40 mm** (50 GHz) and **1.85 mm** (65 GHz)

General Features:

- Simplified Assembly
- Eliminate Screening and Grading
- Mode Free to Rated Frequency

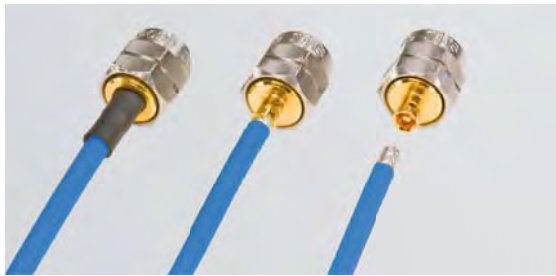

Materials & Finishes

Materials:

- Center Contacts, Housings, Bushings Retaining Rings: Beryllium Copper (BeCu), UNS C17300 Per ASTM B196
- Coupling Nuts: Stainless Steel UNS S30300 Temper Cold Drawn Per ASTM A582
- Contact Capture Bead Rings: High Temperature Ultem 1000 Per ASTM D5205
- Dielectrics (SMA only): Virgin PTFE Fluorocarbon Per ASTM D1710, Type 1, Grade 1, Class B

Finishes:

- Center Contacts, Housings, Bushings: Gold Per MIL-DTL-45204, Type II, Grade C, Over Electroless Nickel Per MIL-C-26074
- Passivated Per ASTM A967

Environmental:

- Operating Temperatures: -55°C to +165°C

Users are cautioned that performance is dependent upon the specific cable selected and cable preparation and termination, which is beyond the control of Southwest Microwave.



Direct Solder Cable Connectors

Super SMA Cable Connectors

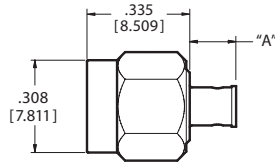
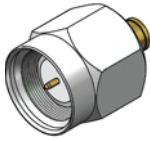

Cable Center Conductor Dia.	Cable	"A"	Cable Connector No.	
.0113	.047	.146	2270-01G	⚠
.0201	.086	.146	2270-02G	⚠
.0253	.086 LL	.179	2270-07G	⚠
.0362	.141	.179	2270-04G	⚠
.0453	.141 LL	.179	2270-05G	⚠
			Male	Female

2.92 mm Cable Connectors

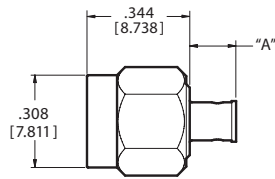

Cable Center Conductor Dia.	Cable	"A"	Cable Connector No.	
.0113	.047	.136	10270-01G	⚠
.0201	.086	.158	10270-02G	⚠
.0253	.086 LL	.137	10270-05G	⚠
.0362	.141	.181	10270-04G	⚠
.0453	.141 LL	.181	10270-06G	⚠
			Male	Female

2.40 mm Cable Connectors

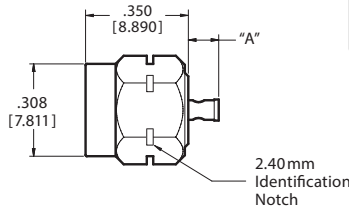

Cable Center Conductor Dia.	Cable	"A"	Cable Connector No.	
.0113	.047	.101	14270-01G	⚠
.0201	.086	.101	14270-02G	⚠
			Male	Female

1.85 mm Cable Connectors

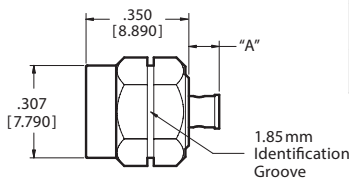

Cable Center Conductor Dia.	Cable	"A"	Cable Connector No.	
.0113	.047	.101	18270-01G	⚠
.0201	.086	.101	18270-02G	⚠
.0126	.047 LL	.101	18270-03G	⚠
			Male	Female

⚠ Not currently released.

Direct Solder Cable Connector Assembly (1.85 mm Illustrated)

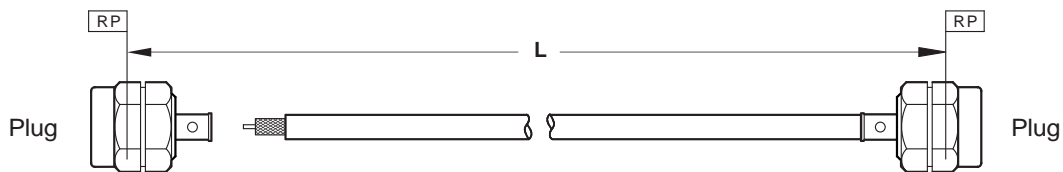

Users are cautioned that performance is dependent upon the specific cable selected and cable preparation and termination, which is beyond the control of Southwest Microwave.



Direct Solder Flange Mount Cable Terminations

Electrical:

- DC to 40 GHz (Mini: DC to 36 GHz) • Low VSWR • Low RF Leakage

Materials/Construction:

- Housing: Unitized Stainless Steel, Gold Plate Per MIL-DTL-45204 (Mini: Beryllium Copper (BeCu), Gold Plated Per MIL-DTL-45204)
- Center Contact: BeCu, Gold Plated Per MIL-DTL-45204
- Capture Bead: ULTEM 1000 Per ASTM D5205
- Dielectric: PTFE Fluorocarbon (Mini: Air)
- Raised Metal Grounding Ring for 360° Metal-to-metal Contact
- Solder Inspection Hole for Center Conductor Alignment and Solder Flow
- Flexible and Semi-rigid Cable

2-Hole .625L Cable Termination (DC to 40 GHz)

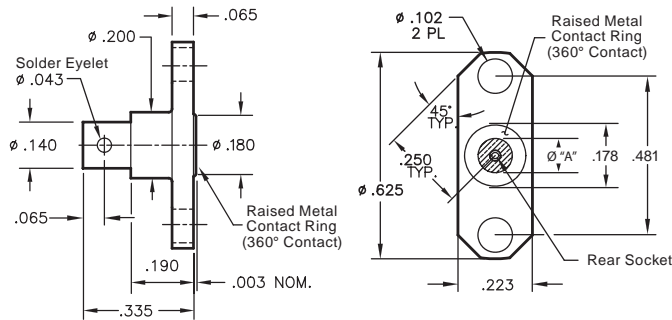

Ø "A"	Cable Center Conductor Dia.	Cable	Accepts Pin Dia.	Cable Conn. No.
.072	.020	.086	.012	107-14G
.076	.020	.086	.015	107-13G
.104	.020	.086	.020	107-12G

2-Hole .550L Cable Termination (DC to 40 GHz)

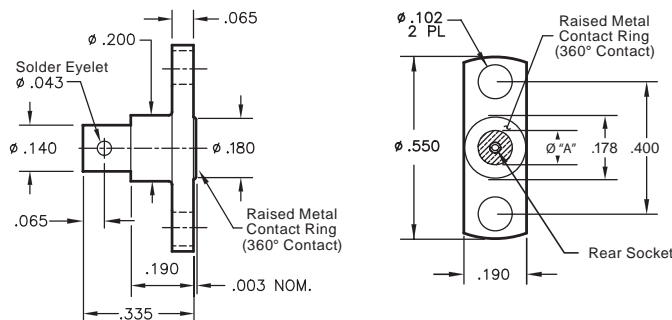

Ø "A"	Cable Center Conductor Dia.	Cable	Accepts Pin Dia.	Cable Conn. No.
.072	.020	.086	.012	108-14G
.076	.020	.086	.015	108-13G
.104	.020	.086	.020	108-12G

2-Hole .270L (Mini) Cable Termination (DC to 36 GHz)

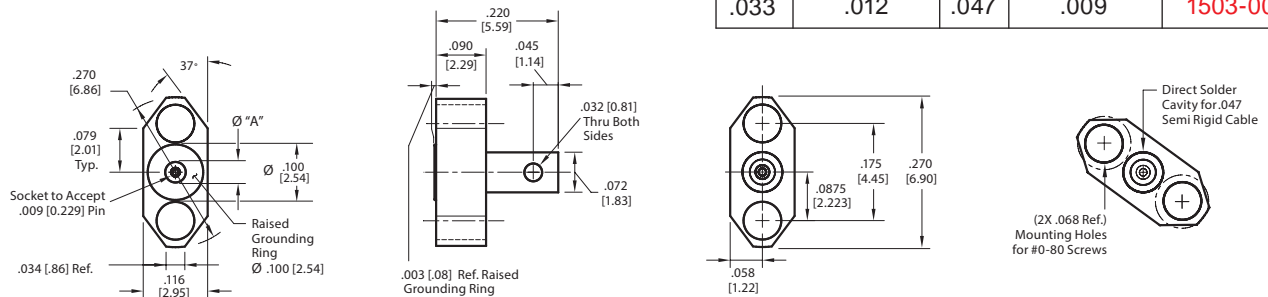

Ø "A"	Cable Center Conductor Dia.	Cable	Accepts Pin Dia.	Cable Conn. No.
.033	.012	.047	.009	1503-00G

Users are cautioned that performance is dependent upon the specific cable selected and cable preparation and termination, which is beyond the control of Southwest Microwave. Unless otherwise indicated, all dimensions are in inches.

Typical Test Data

To electrically evaluate the Flange Mount Cable Terminations, a back-to-back pair was inserted in line into a reference cable assembly and tested to 40 GHz.

The data shows the reference cable (Assembly 1) and the cable assembly with the Cable Terminations added (Assembly 2) overlaid. The difference is the contribution of the two added Cable terminations.

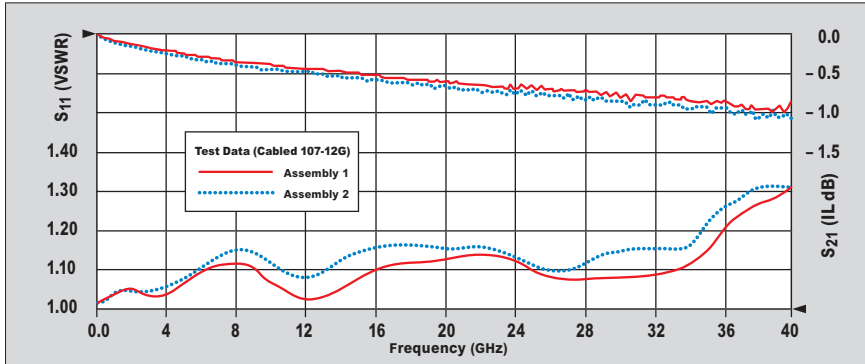

The diagrams below show the test configurations:

Reference Cable – Assembly 1

2.92 mm Male-to-Male Cable Connector Assembly

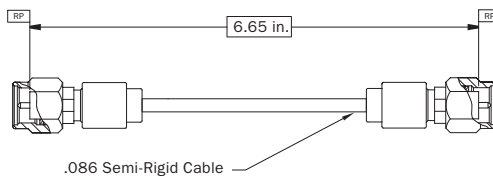

Reference Cable – Assembly 2

Cable Assembly 1 “Split” and Reconnected with (2) Flange Mount Cable Termination Connectors.

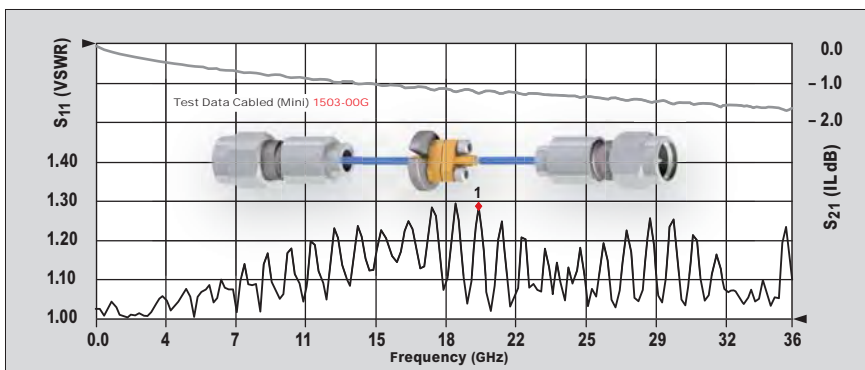
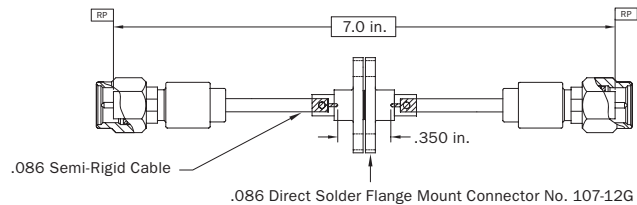

The data above is for 2 sets of 2.92 mm field-replaceable cable plug/male connectors with .047 Flex Cable terminated to connector 1503-00G. The two 1503-00G connectors are terminated back-to-back with .009 inch dia. pin and are attached to a base plate to simulate panel mounting. Both cables have the same electrical length, RP to RP = 6 inches. Results may vary by cable selected and assembly method. Contact Southwest Microwave for Assembly Instructions.

Users are cautioned that performance is dependent upon the specific cable selected and cable preparation and termination, which is beyond the control of Southwest Microwave.